

Sampling Procedures for Filter Effectiveness by Matched Weight Monitor

1. Summary of Test Method. A 1 gallon sample of aviation turbine fuel is taken from an in-line sample port downstream of a filter/separator while fuel is flowing and filtered through a monitor that contains two matched weight membrane filters. The matched weight monitor (MWM), commonly referenced by the Millipore tradename, is identified by the yellow and red protective plugs. An illustration of the test equipment is shown in Figure 1. Once the sampling process is complete, the remaining fuel inside is removed from the outlet side of the monitor and the MWM is packaged for submittal to the nearest petroleum laboratory.

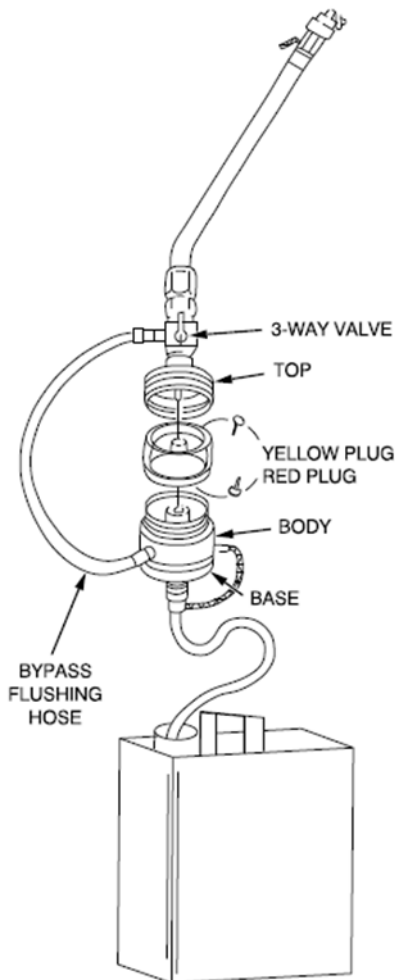

Figure 1: Overview of MWM Test Equipment

2. Significance and Use. The purpose of Filter Effectiveness (FE) testing is to evaluate the amount of particulate contamination in the fuel downstream of the filter/separator in order to ensure the filter/separator is performing to standard. All filter/separators in service are required to be sampled for FE testing within 30 days from the last sample date. Particulates are one of the most common contaminants found in fuel storage and

Enclosure 12 to FTL 22-01 (Change 1)

dispensing systems and FE testing is intended to be an ongoing check of filter/separator performance to ensure clean fuel is being issued.

3. Equipment.

a. Kit, Fuel Sampling (includes in-line sampler, hose, vacuum syringe, case), NSN: 6665-00-496-9623 or 6630-01-230-2652

b. Matched Weight Monitors (Box of 48), NSN: 6630-00-764-5761

c. Bottle, 1-quart, Clear Glass, NSN: 8125-00-378-9994

d. Sample Can, 1-Gallon (Epoxy Lined), NSN: 8110-01-371-8315

e. Sample Can, 1-Gallon (Rectangular, F-Style), NSN: 8115-00-224-7935

4. Procedures.

a. The mandatory method of collecting FE samples is through the use of the “quick-connect” adaptor, installed permanently in the fuel system piping on the downstream side of a filter/separator. Using this adaptor permits sampling with an in-line sampling device. The quick-connect adaptor must already be installed before starting these procedures.

b. Prior to starting the sampling procedures, the fuel system being sampled must already be in a state of flow or recirculation at the normal operating pressure and flowrate (i.e. HEMTT high idle) for a minimum of 3 – 5 minutes. This ensures that the filter/separator is operating as intended at the time of sampling and that there is sufficient pressure for proper flow through the sampling device.

c. Inspect the sampling adapter and sampler assembly for any visible particulate, sediment, rust, or other material. If present, remove it with a clean, lint-free cloth.

d. Select a MWM and remove the protective plugs from the top and bottom. Put both plugs aside in a clean, safe place to be replaced after sampling is complete.

NOTE

The MWM is identified by the protective plugs that are yellow and red. Do not use the monitors with blue and red plugs for this method.

e. Unscrew the sampler cover from the sampler base and place the MWM into the sampler base with the outlet side (red plug side, also noted as the “spoke” side, “wagon wheel” side, or “spider web” side) facing down (Figure 2).

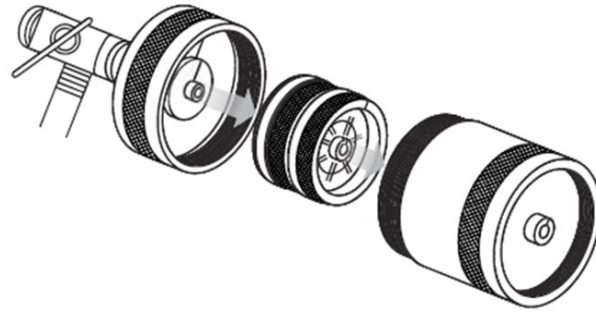

Figure 2: Monitor and Sampler Base

NOTE

It is imperative that the monitor is placed in the adapter correctly so that the fuel flows from inlet to outlet (Figure 3). If it is placed in the sampler upside down, the sample will be invalid.

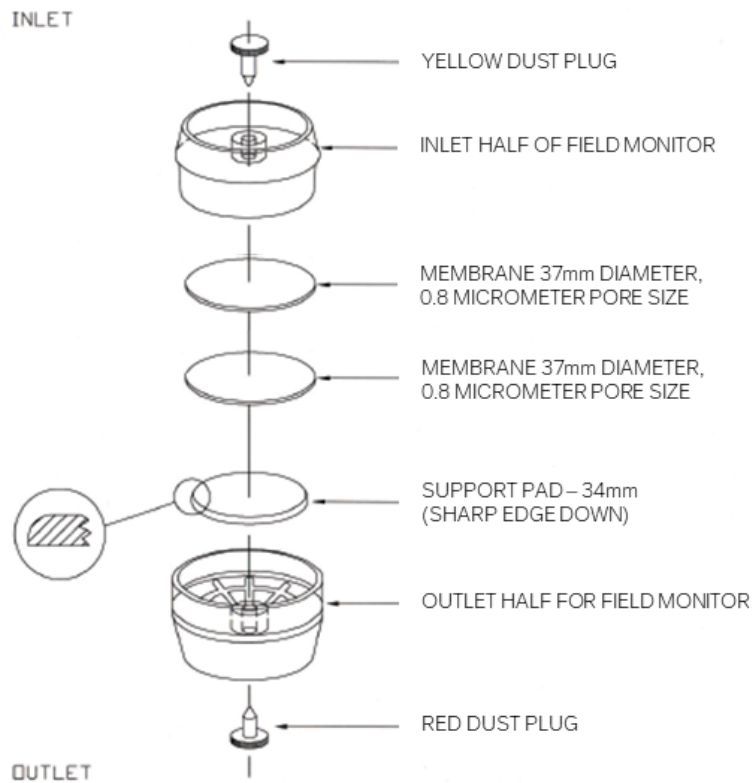

Figure 3: MWM Construction

f. Insert the sampler base (with monitor in place) into the sampler cover and screw the two pieces together to a snug hand-tightness.

g. Connect the bypass hose from the selector valve to the bypass port on the base (Figure 4). Press the hose down firmly into the port for a tight fit.

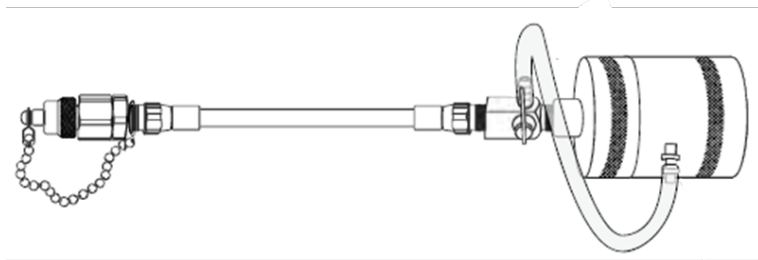

Figure 4: Connecting Bypass Hose

h. If not already connected, screw the outlet hose onto the sampler base. Depending on the type of sampler, it may also be necessary to ensure there is a nylon plug inserted into the open port on the side of the sampler base opposite the bypass hose to prevent leakage (Figure 5).

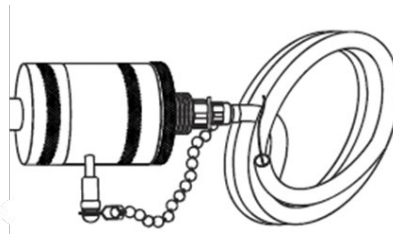

Figure 5: Outlet Hose

CAUTION

The selector valve must be in the OFF position before attaching the sampler to the quick-connect valve (Figure 6).

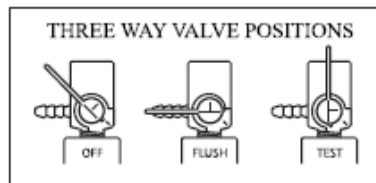

Figure 6: Three Way Valve Positions

- i. Remove the protective dust caps from quick-connect valve and the sampler.
- j. Attach the ground wire by clamping one end to the sampling assembly and the other end to a proper grounding point (Figure 7).

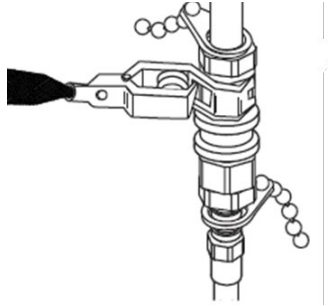

Figure 7: Attach the Ground Wire

WARNING

The sampling assembly must be properly grounded to avoid possible fire or explosion from static electrical charges.

k. Connect the sampling assembly to the sampling valve connection by inserting the sampler nipple into the quick-connect valve collar (Figure 8). Retract the valve collar and insert the nipple firmly into the valve. Release the collar when the nipple is seated.

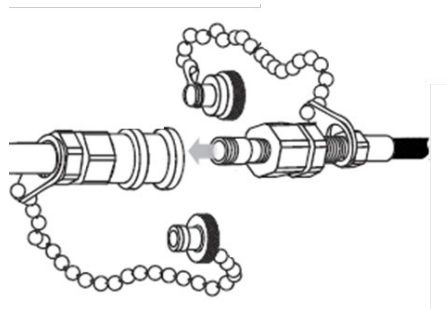

Figure 8: Connecting the Sampling Assembly

l. Place the end of the outlet hose into the 1 liter sample bottle and turn the selector valve to the FLUSH position.

m. Flush the sampling assembly with approximately 1 liter of fuel. While the valve is in the FLUSH position, fuel runs through the bypass flushing hose and not through the MWM.

n. Turn the selector valve to the OFF position and place the end of the outlet hose into a 1 gallon sample can.

o. Turn the selector valve to the SAMPLE position. Flow 1 gallon of fuel through the MWM.

p. When the 1 gallon can is full, turn the selector valve to the OFF position.

q. Disconnect the sampling assembly from the sampling valve connection and detach the ground wire. Replace the two protective dust caps (one on the sampling connection and the other on the sampler assembly).

r. Unscrew the sampling assembly and remove the MWM.

s. Use the vacuum syringe to remove any fuel remaining inside of the monitor by connecting the syringe to the outlet (“spoke” side) of the monitor and pumping two to three times and pointing the outlet of the syringe into a waste container (Figure 9).

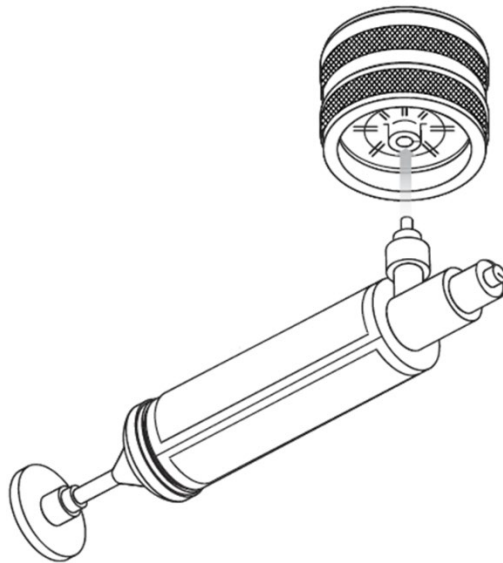

Figure 9: Vacuum Syringe Assembly

t. Replace the yellow and red protective plugs and wipe the outside dry with a clean, lint-free cloth. Do not open it.

u. Ensure that the monitor has the appropriate sample information affixed and that it is packaged properly for transport or shipment to the supporting laboratory for analysis. It is recommended that the monitor is placed in a plastic slide-seal bag together with the DD Form 2927 sample tag, sealed, and placed inside of a padded envelope for shipping. See Enclosure 7 for complete instructions on filling out the sample tag.

NOTE

Once received, the lab will analyze the sample by conducting standardized procedures, which includes flushing the MWM with solvent, drying the filters, weighing the filters, and calculating the amount of particulate present. The lab will provide the submitting organization with a test report containing the result in units of milligrams per liter (mg/L).

Enclosure 12 to FTL 22-01 (Change 1)

5. Reporting Requirements.

a. PASS - a result of 1.0 mg/L or below.

b. FAIL - a result greater than 1.0 mg/L. If a failing test result is reported by the lab, the fuel source in question will immediately be placed on quality hold and the source will be investigated further, including a resample being submitted to the lab. A confirmed failure of a second FE sample requires the filter elements to be replaced, updated with DATE CHANGED stenciled with the month and year on the filter/separator housing, and the process to begin anew.